

Wagon wapniarka serii Swddx typu 69W

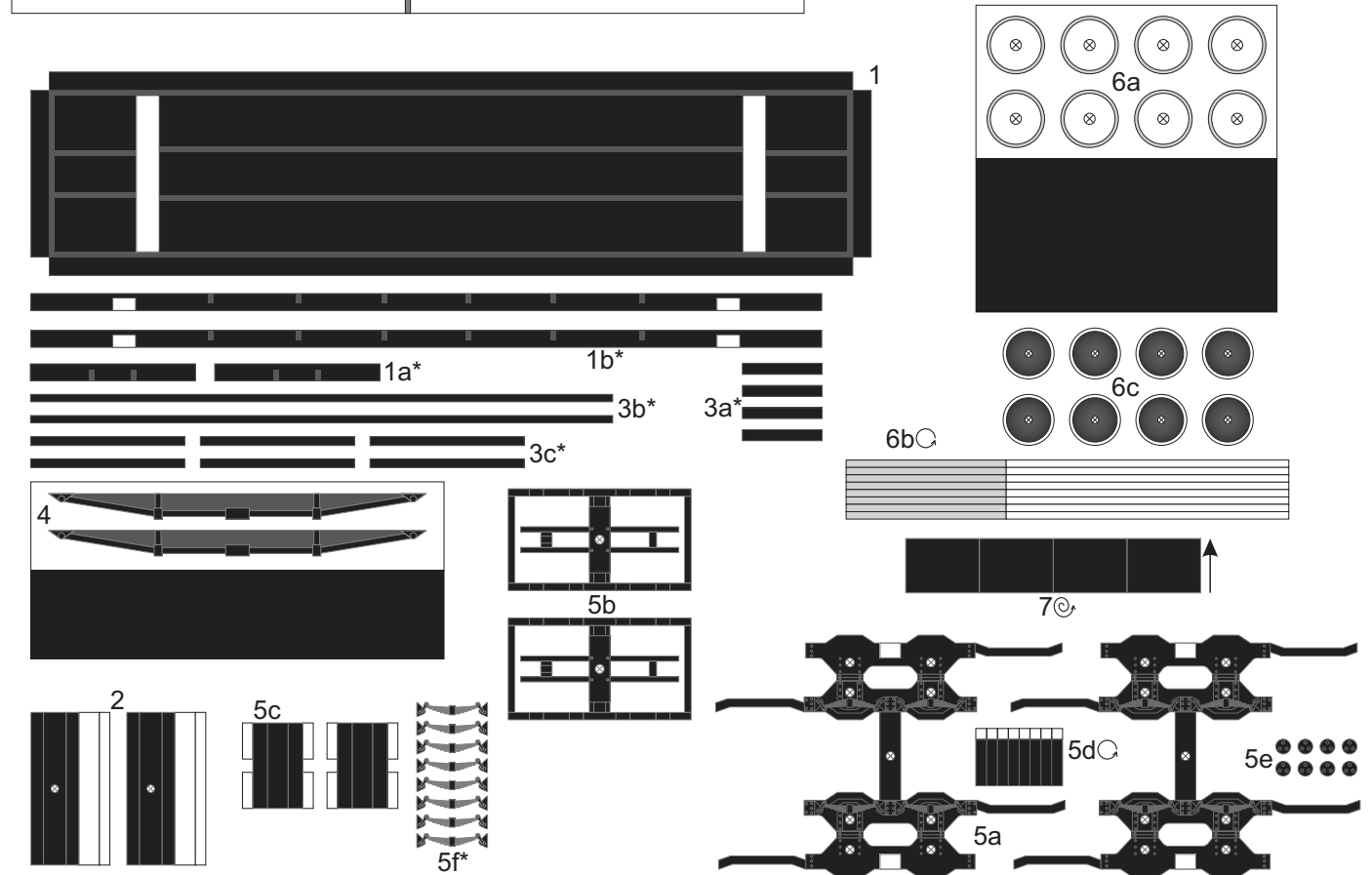

Instrukcja

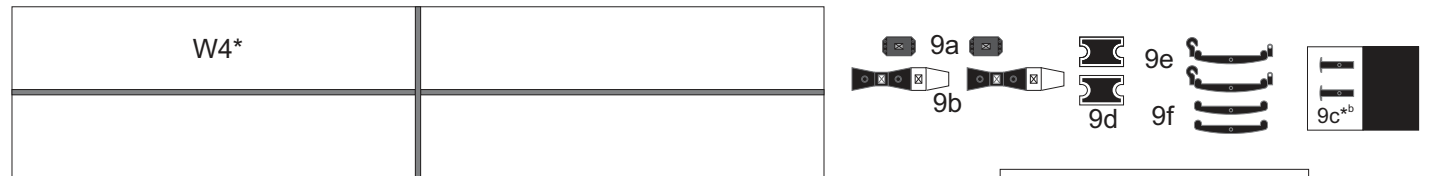
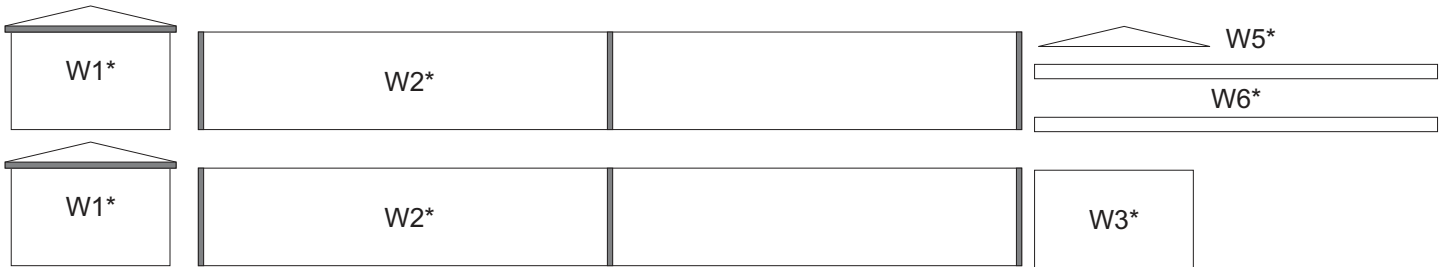
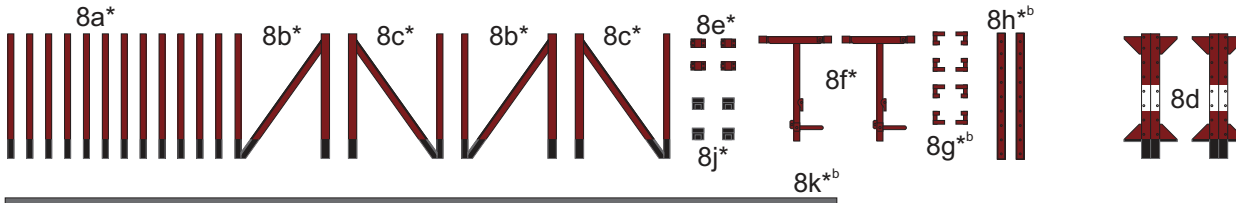
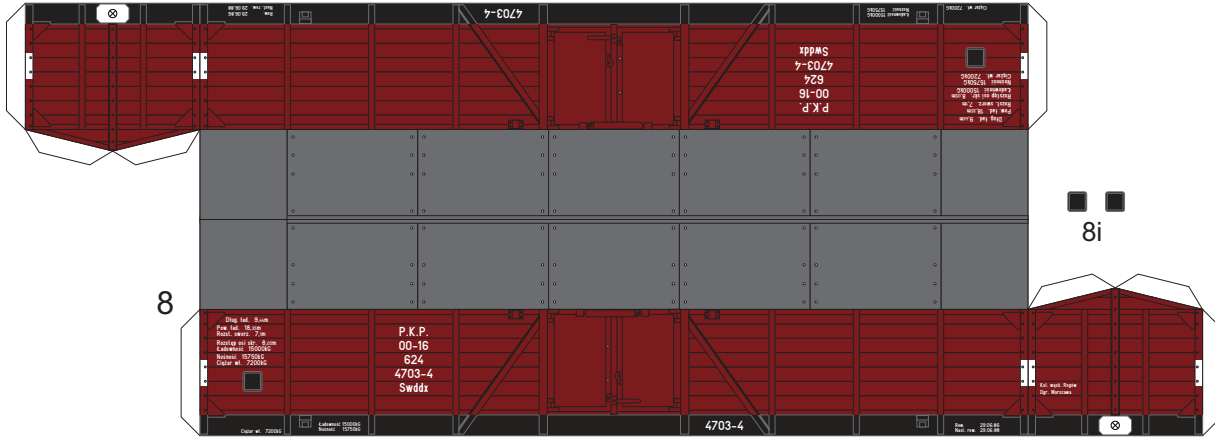
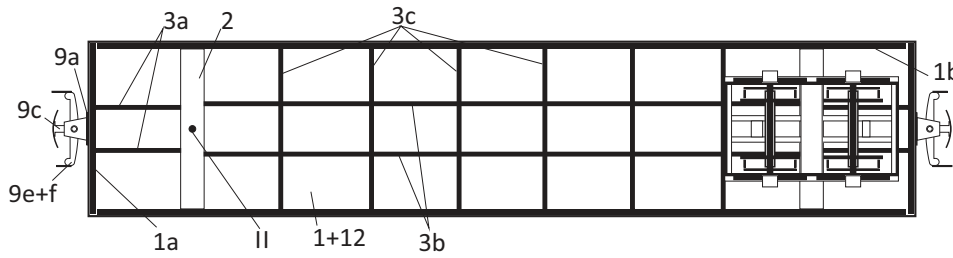
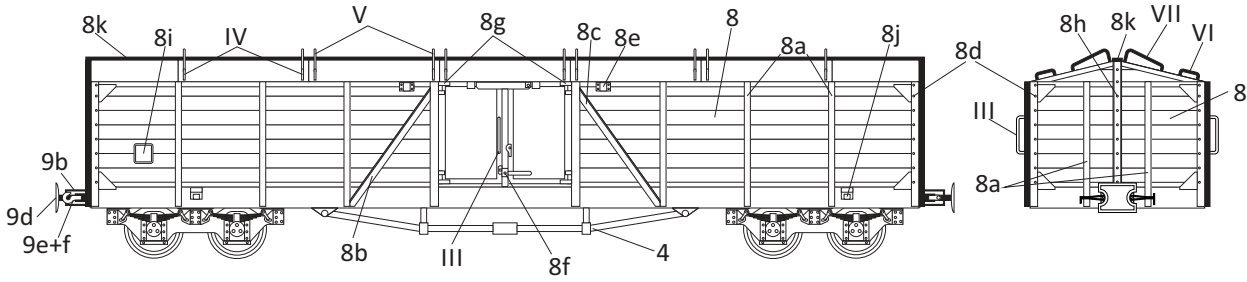

Schemat montażu wręgów

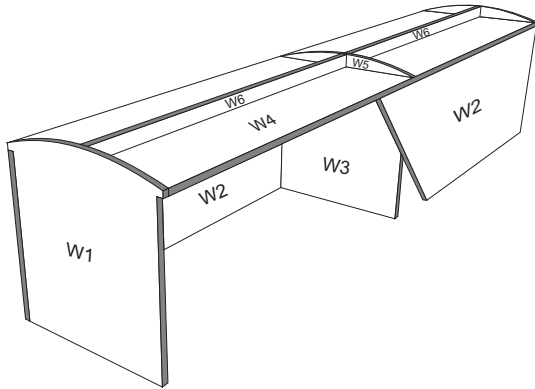

Wózki
(skala 1,5:1)

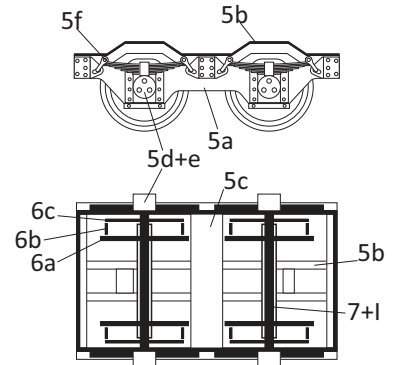

Objaśnienia

- *^b - podkleić brystolem
- * - podkleić kartonem 0,5mm
- ⊙ - zwinąć w walec (widoczny tylko fragment zabarwiony)
- ⊙ - zwinąć ciasno
- ➔ - kierunek zwijania

Elementy do wykonania z drutu

- I - Ø1,0mm - 4szt.
- II - Ø1,0mm - 2szt.
- ⌒ III - Ø0,25mm - 2szt.
- ⌒ IV - Ø0,25mm - 20szt.
- ⌒ V - Ø0,25mm - 20szt.

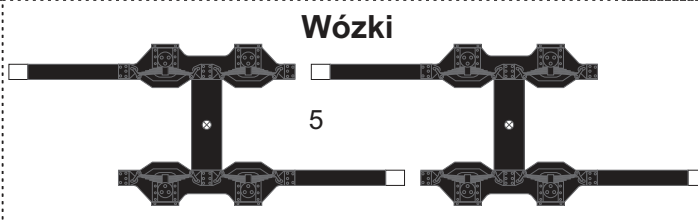
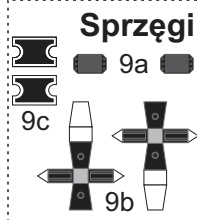

Belki skrętowe dla modelu bez elementów ostoi (tj. 1a, 1b, 3...)

