

Wagon węglarka serii Wddxh typu 60W

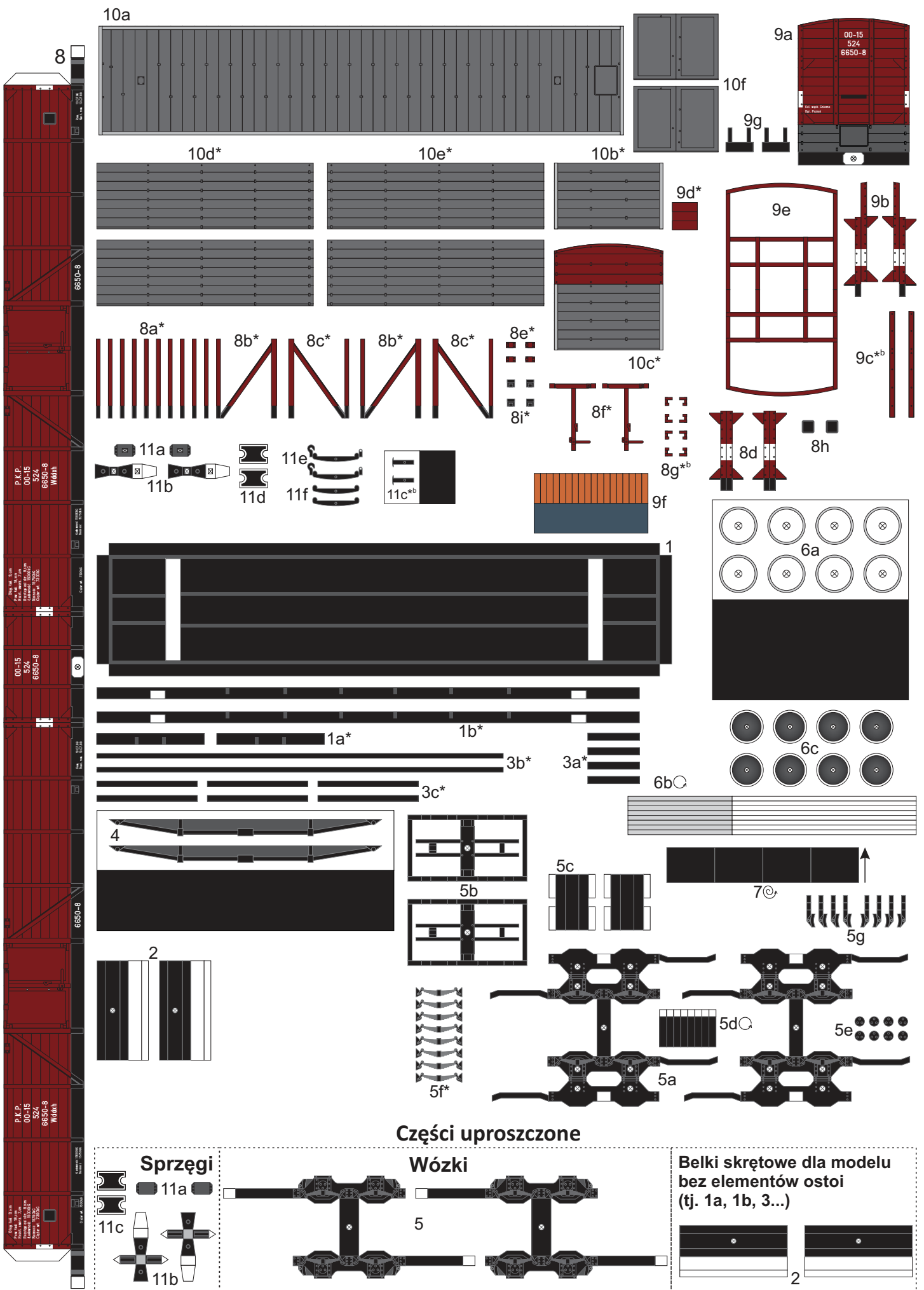

Części uproszczone

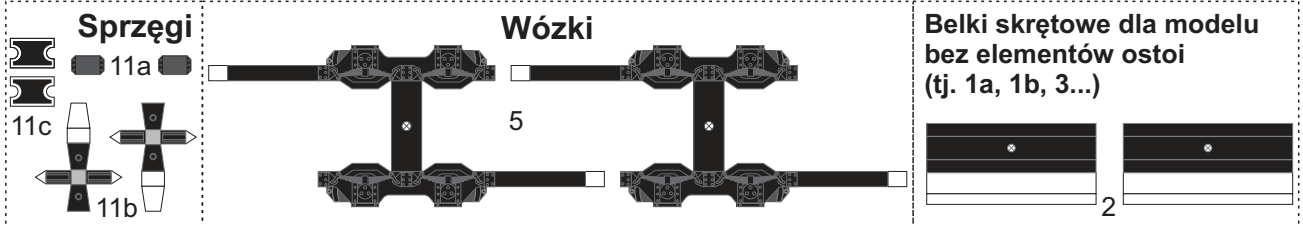

Instrukcja

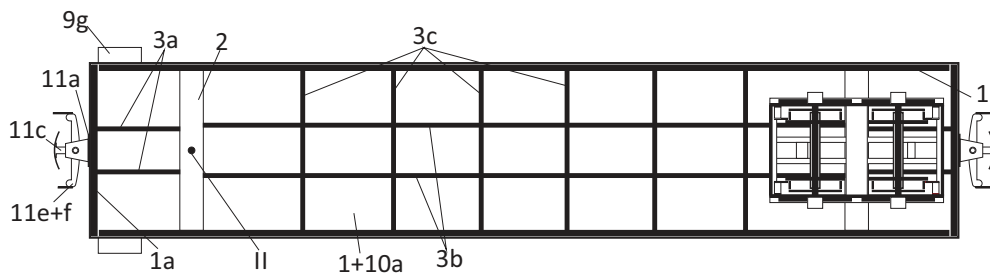
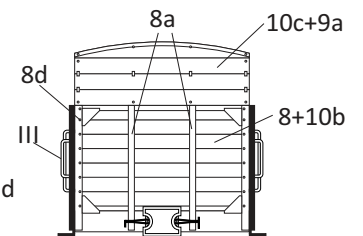
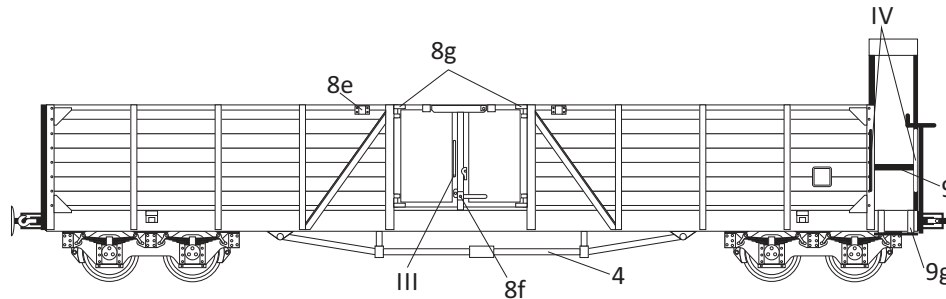
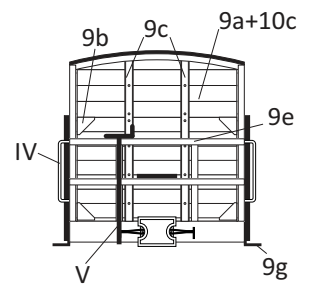
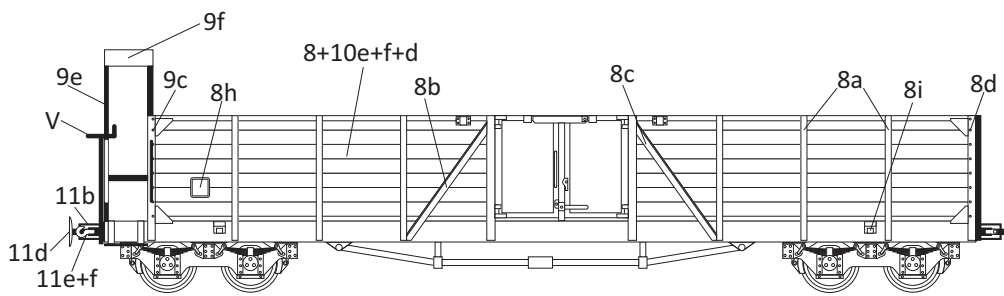

Wózki

(skala 1,5:1)

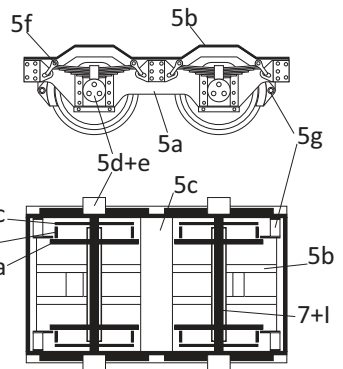

Wnętrze

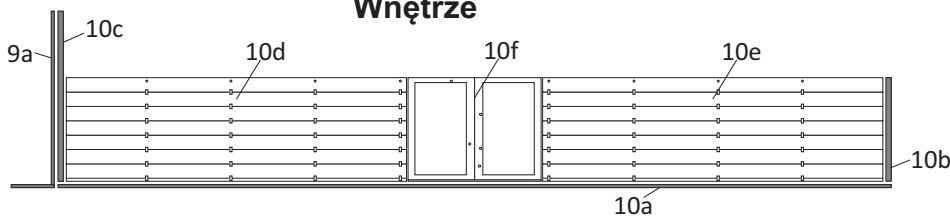

Objaśnienia

*^b - podkleić brystolem





* - podkleić kartonem 0,5mm

⊙ - zwinąć w walec (widoczny tylko fragment zabarwiony)

⊙ - zwinąć ciasno

➔ - kierunek zwijania

Elementy do wykonania z drutu

-  I - Ø1,0mm - 4szt.
-  II - Ø1,0mm - 2szt.
-  III - Ø0,25mm - 2szt.
-  IV - Ø0,25mm - 4szt.
-  V - Ø0,5mm - 1szt.